

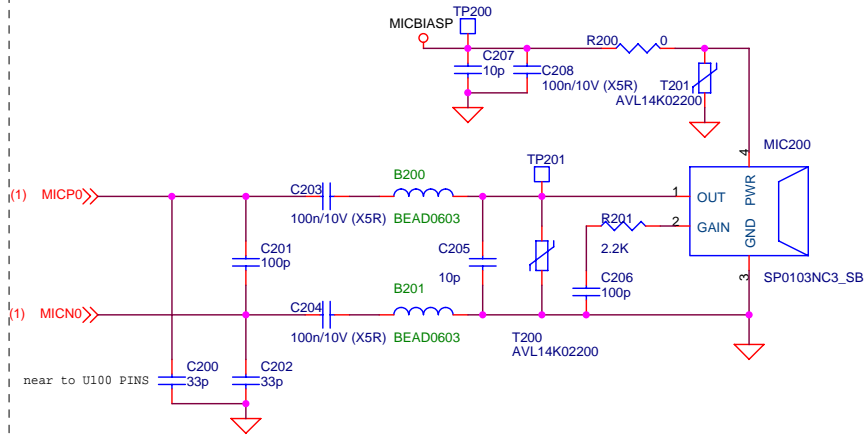

# MICPHONE

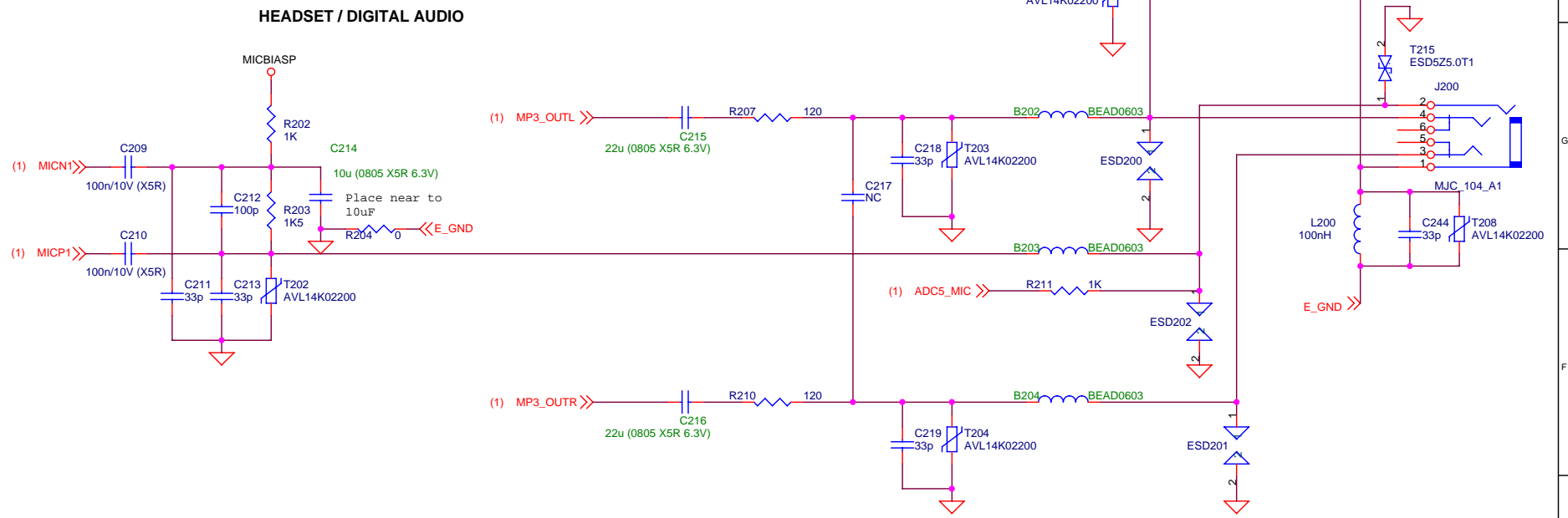

# STEREO HEADSET JACK



# KEYPAD\_CONNECTOR

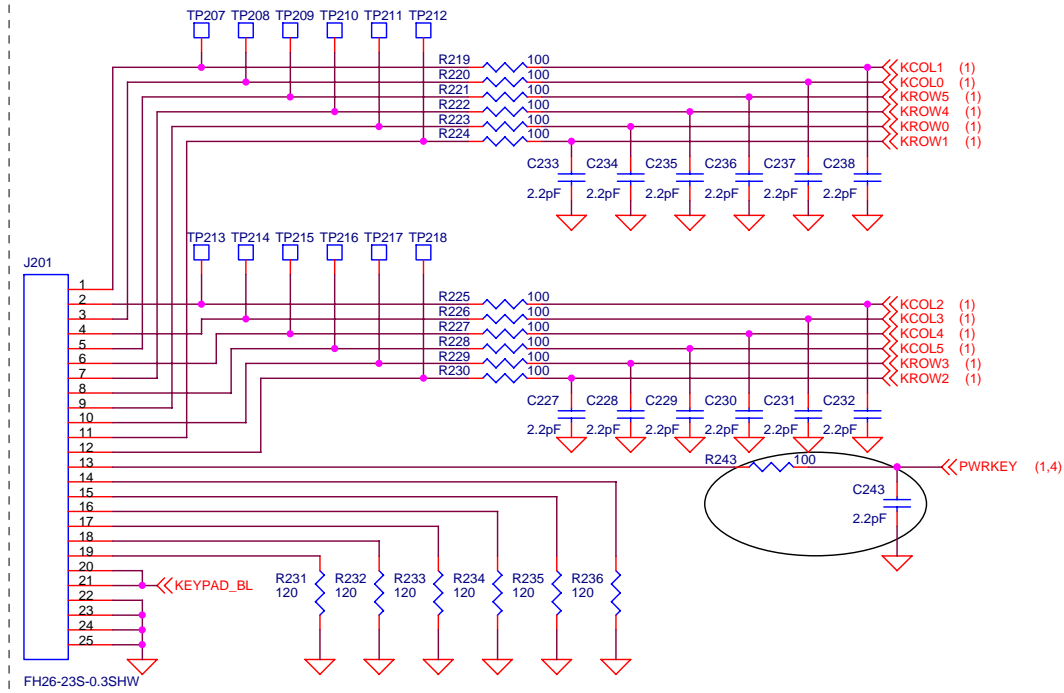

# RECEIVER\_SPEAKER

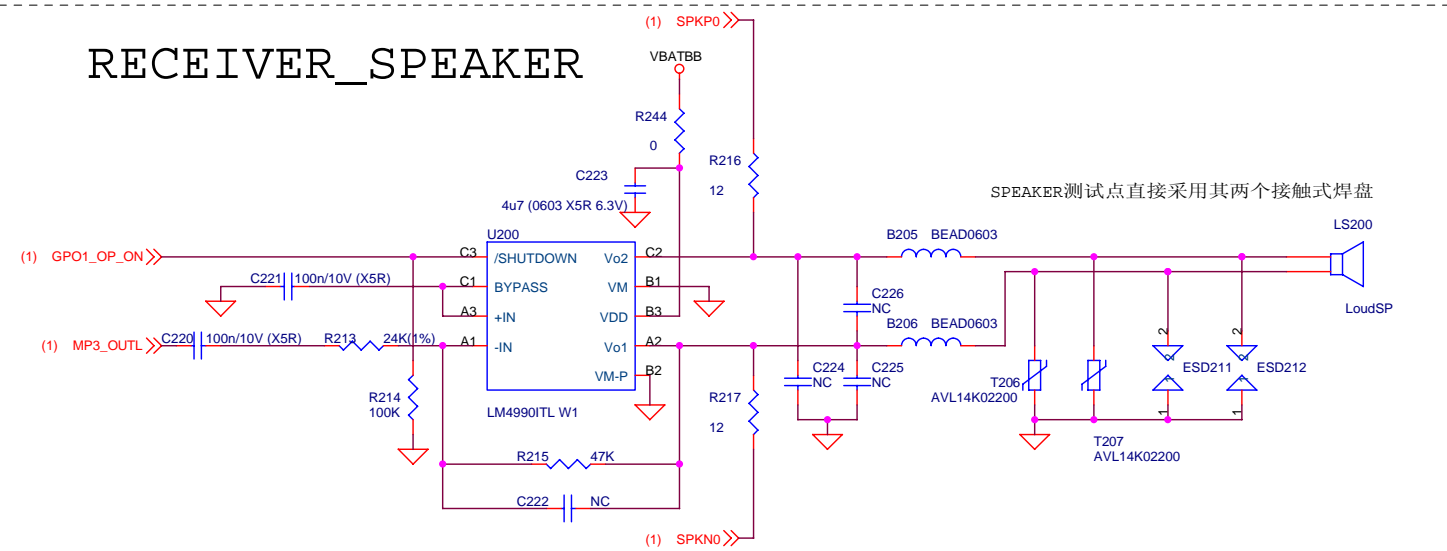

# SIDE\_KEY

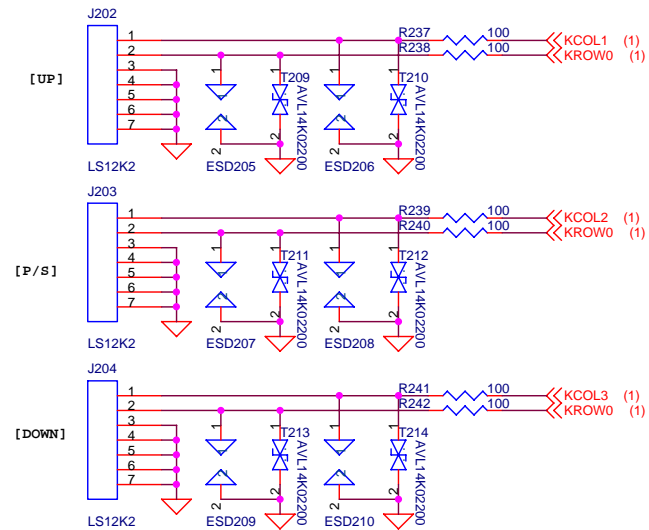

# KEYPAD\_BACKLIGHT

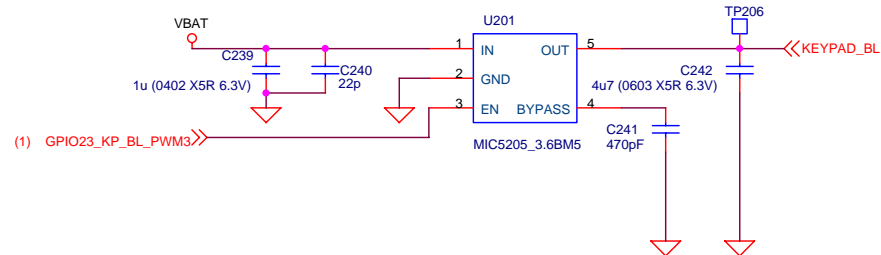

Title		<b>MK11_V3.0</b>	
Size	A3	Document Number	2 Audio,Keypad
Date:	Friday, July 14, 2006	Sheet	2 of 6

### 3 IN 1 Memory

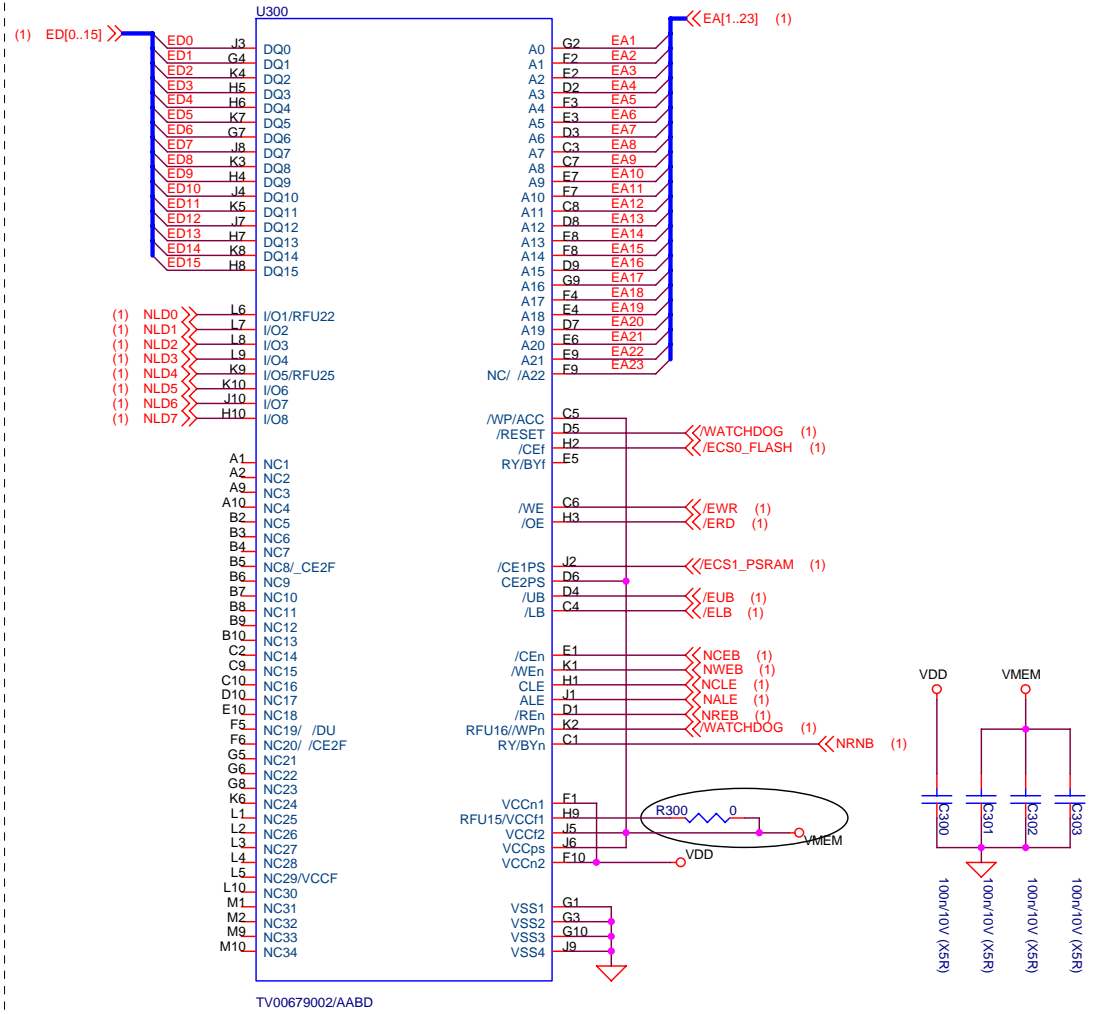

### MINI SD CARD

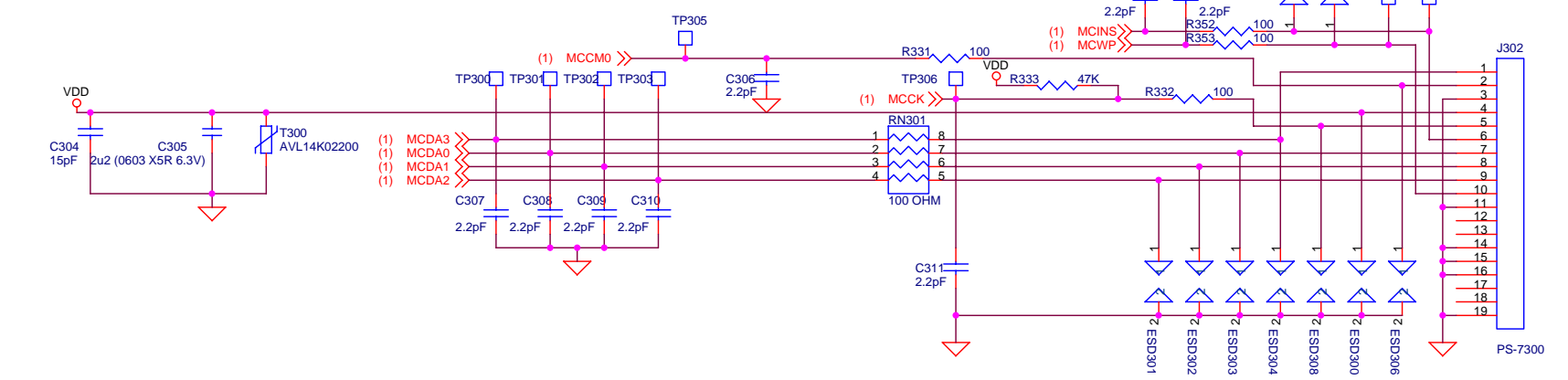

### CAMERA FLASH LED

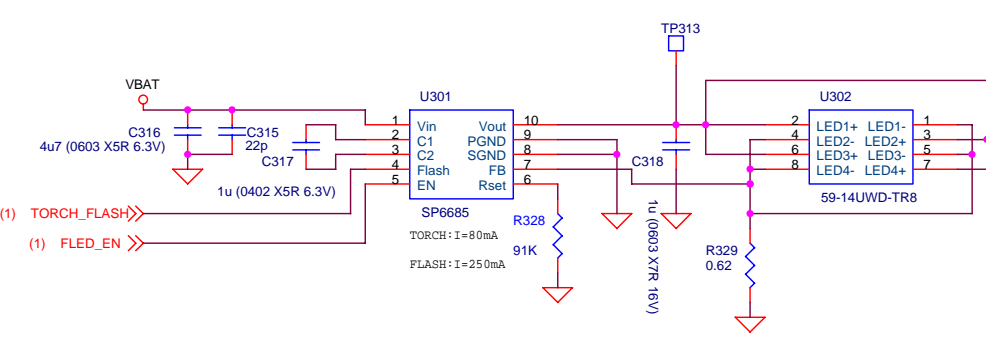

### LCM BACKLIGHT

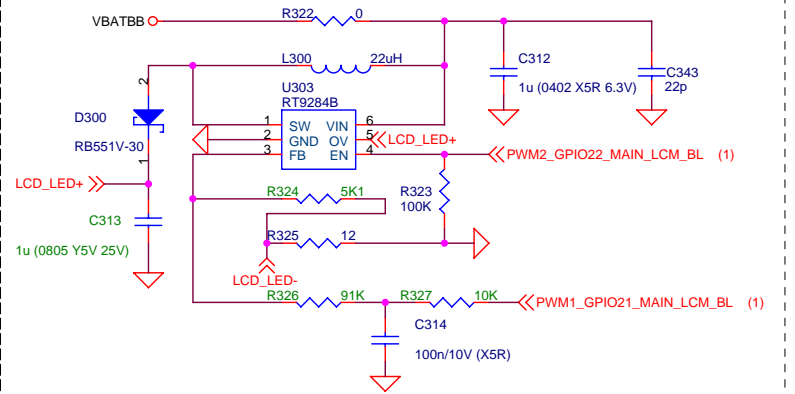

### 2M CAMERA

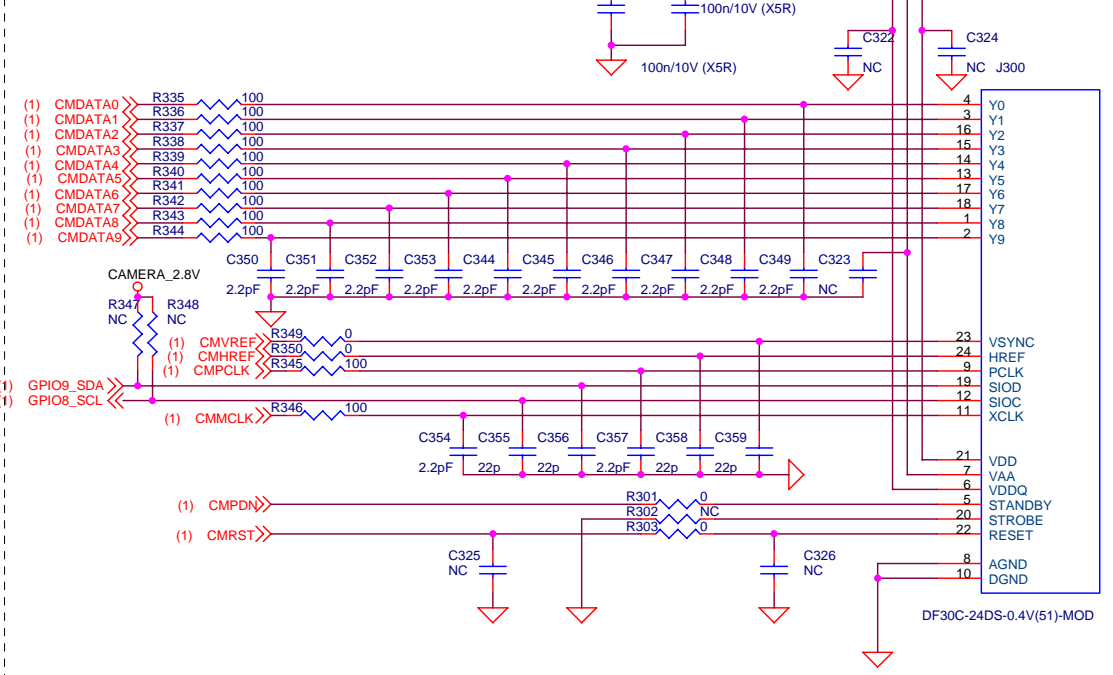

### 1.9" LCM

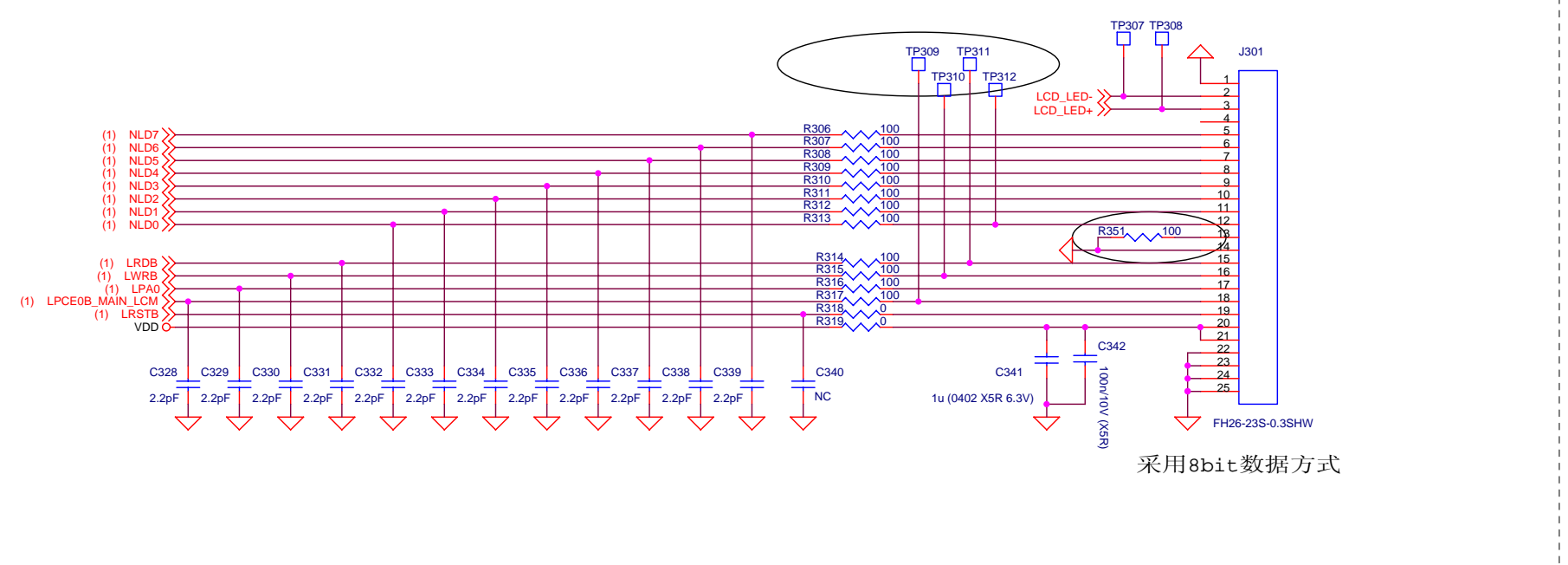

Title		<b>MK11_V3.0</b>	
Size	A3	Document Number	3 SD card, Camera, LCM, Memory
Date:	Wednesday, May 17, 2006	Sheet	3 of 6

# CHARGE MANAGE

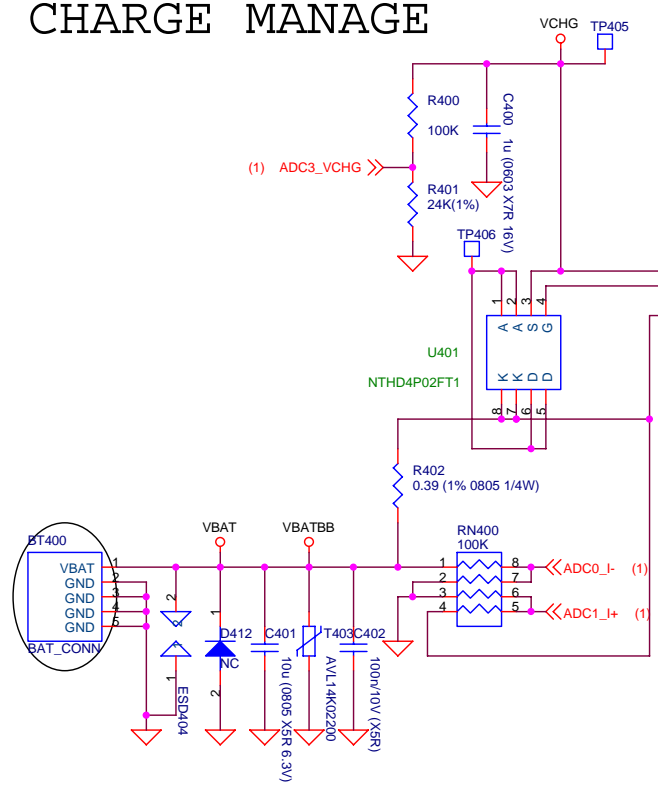

PIN 3 "GND" : Vcore = 1.2V and Vrtc = 1.2V  
 PIN 3 "Floating" : Vcore = 1.8V and Vrtc = 1.5V

# VIBRATOR

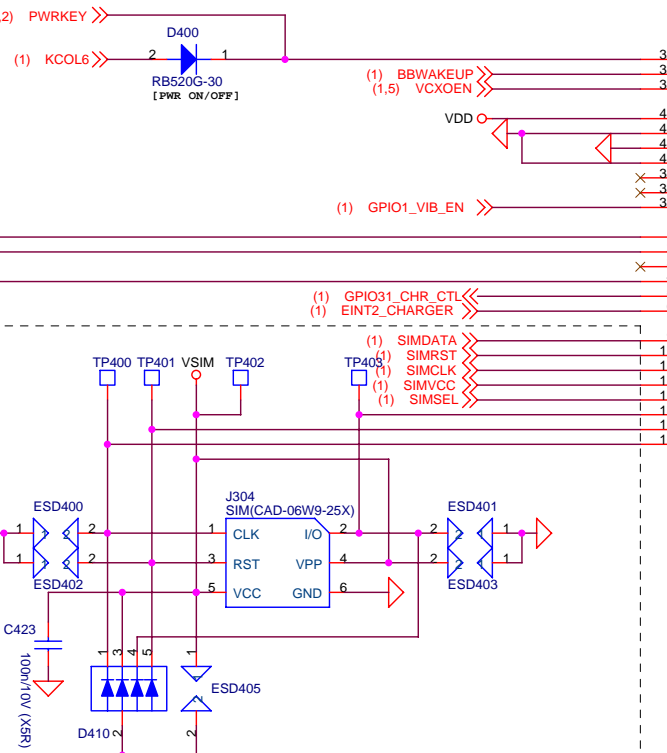
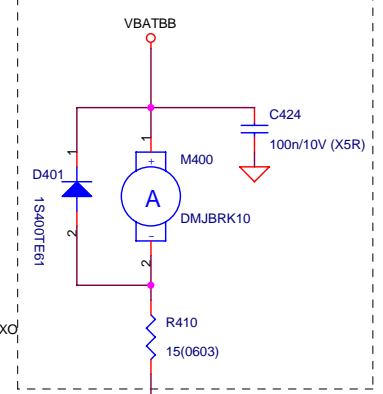

# SIM CONNECTOR

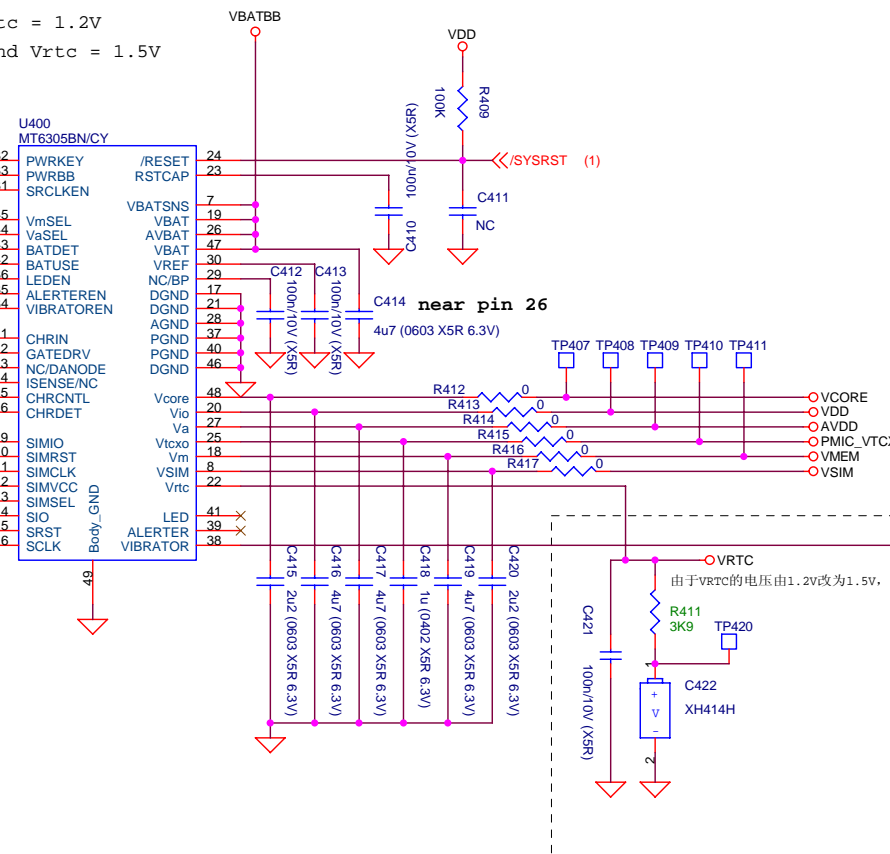

# BACK BATTERY

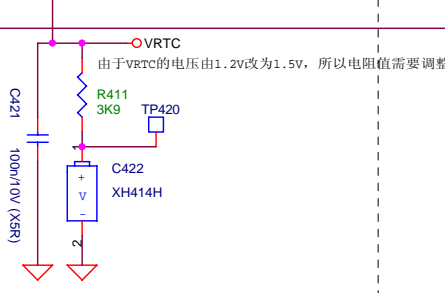

# MINI USB CONNECTOR

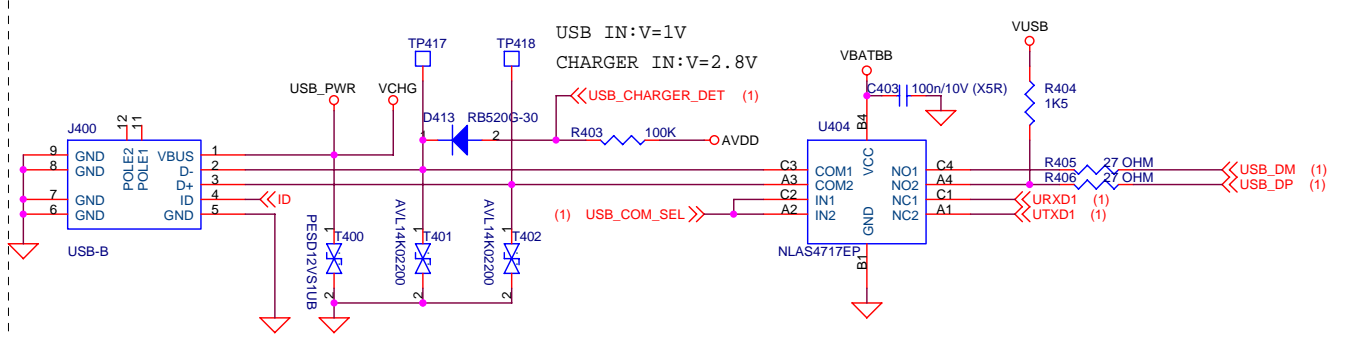

# USB 3.3V LDO

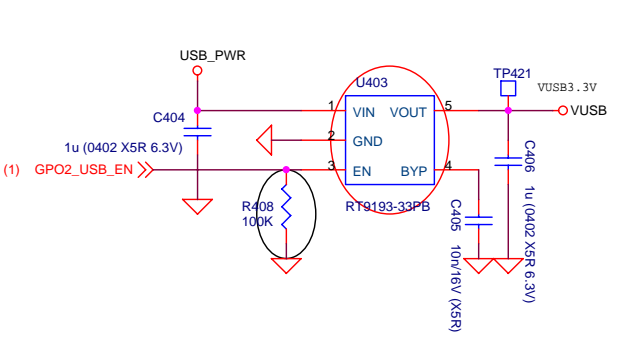

# 1.8/2.8 CAMERA LDO

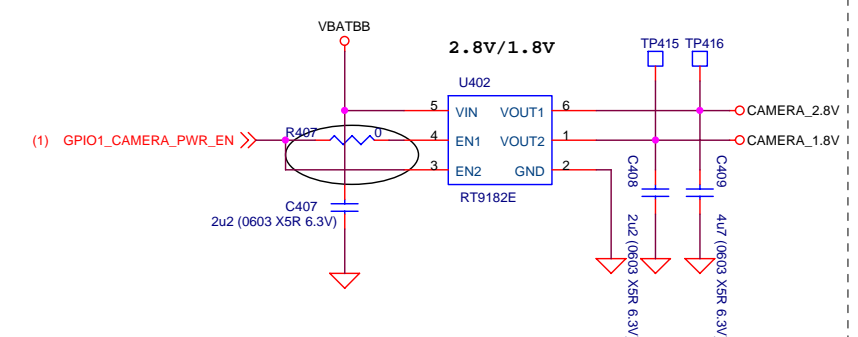

# AUTO POWER ON

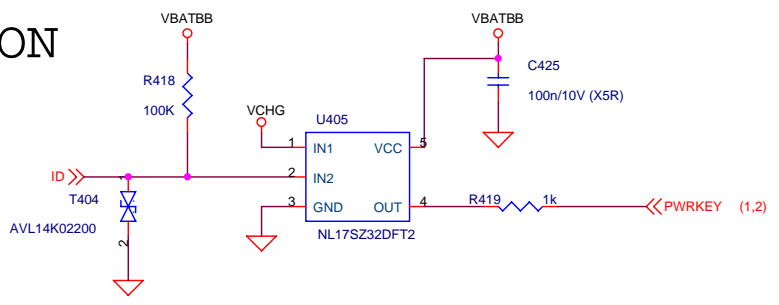

Title		<b>MK11_V3.0</b>
Size	A3	Document Number
		4 Power, SIM, USB, Vibrator
Date:	Wednesday, May 10, 2006	Sheet 4 of 6

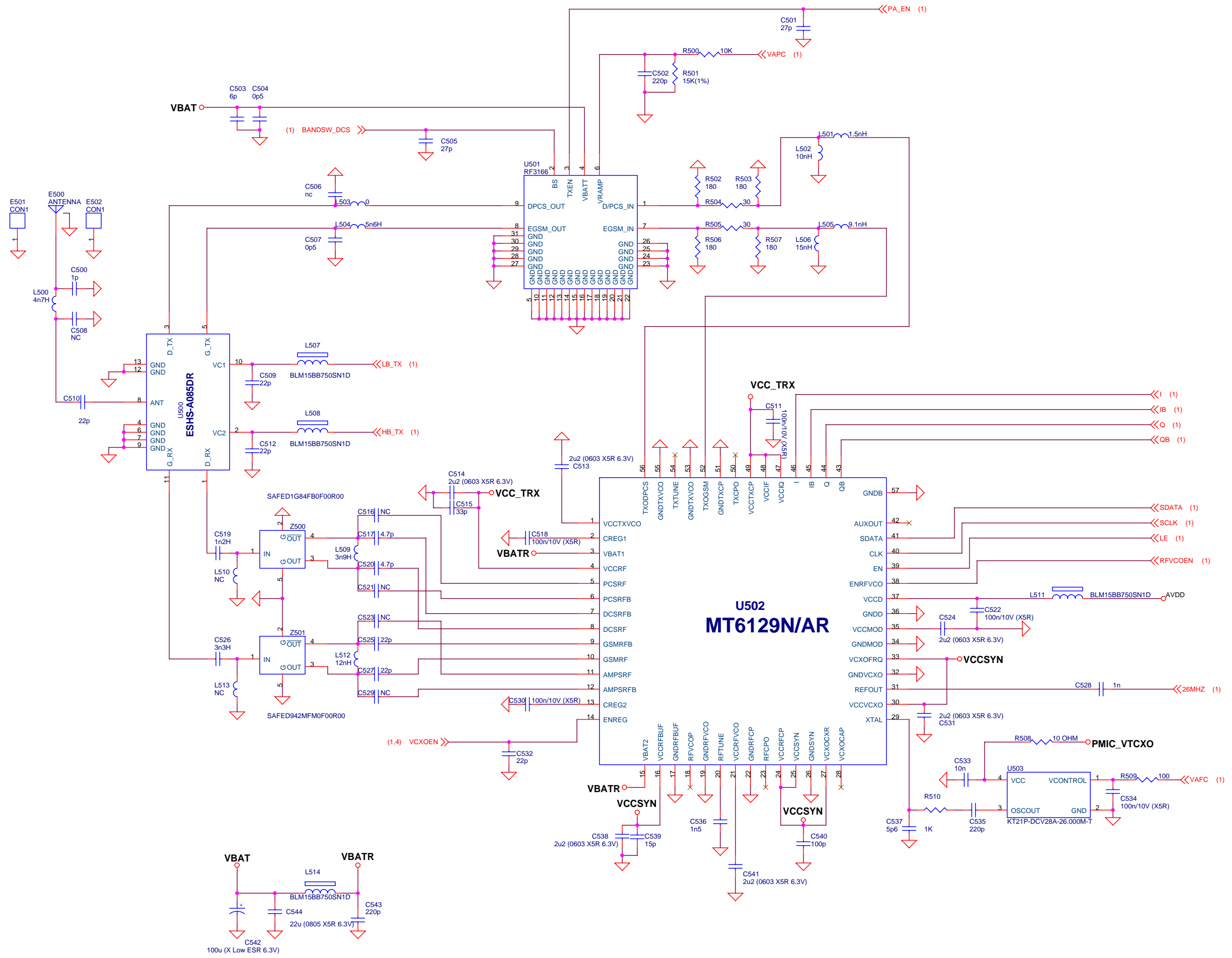

Title		
<b>MK11_V3.0</b>		
Size	Document Number	Rev
A3	5 MT6129, RF3166	
Date:	Wednesday, May 10, 2006	Sheet 5 of 6

